



IR302-FQ33

**WINDAR PHOTONICS**

# OVERVIEW

**Developer of durable, high quality cost-effective LiDAR products which increase the efficiency and revenues of wind energy projects**

- Pioneer of applying and promoting LiDAR sensors for turbine optimisation to the wind industry
- Retrofit market total potential market – up to 300,000 units
- OEM total market potential – 20-25,000 units pa

**Short term – strategic sales focus:**

- Retro-fit market segment North America, Europe and Japan focused on specific turbine platforms
- Selected existing customer relationships in China

# WindEYE Gen3



## Features:

- Laser unit integrated with the Optical Head
- Portable Design
- Increased Durability
- Better performance in elevated nacelle temperatures.
- Increased data availability.

**Windar Services:  
Dynamic Yaw Realignment**

## Dynamic Yaw Control - WindTIMIZER

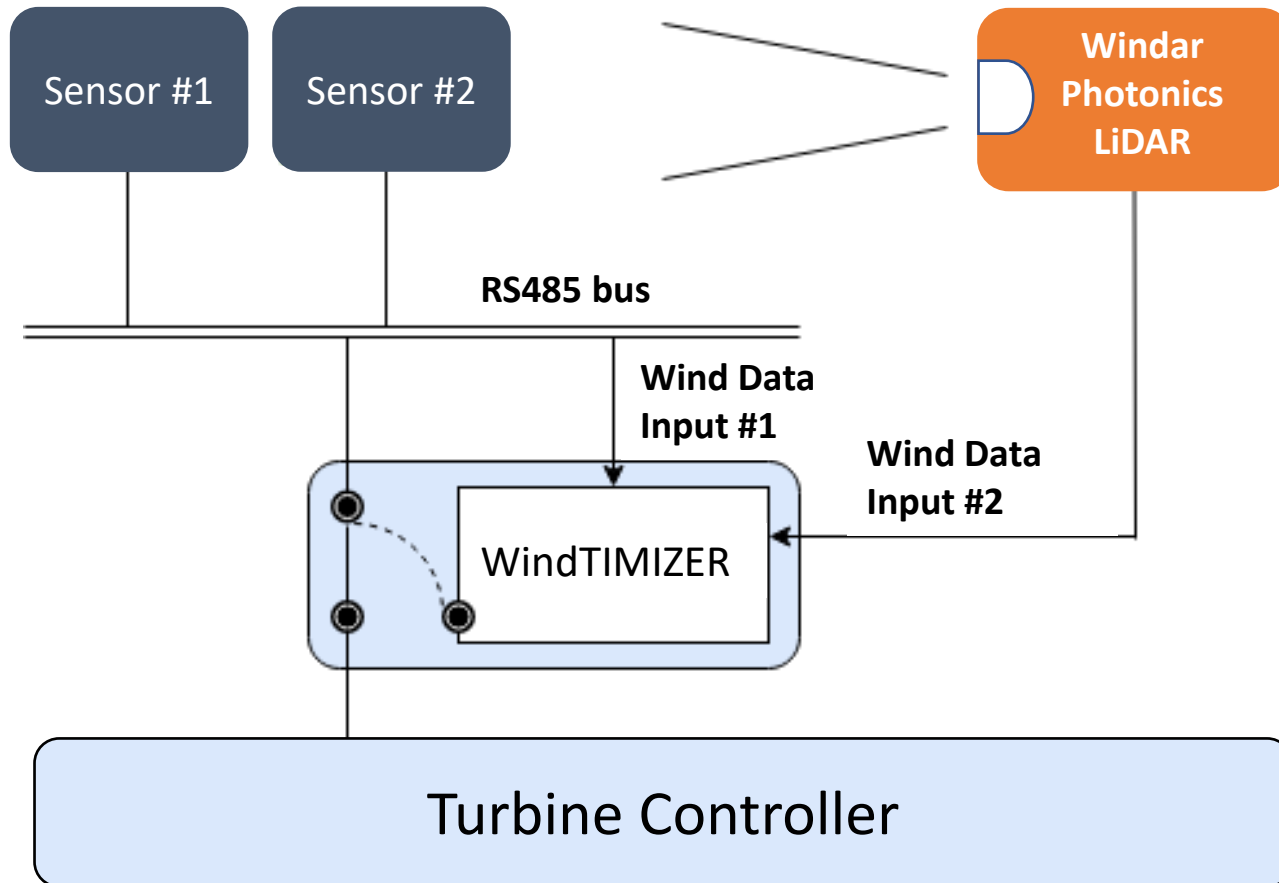

To enable the dynamic yaw correction feature of the WindEYE™, the LiDAR needs to be integrated with the wind turbine control system.

The WindTIMIZER is a mediator that allows the LiDAR to integrate with the wind turbine control system and the legacy anemometry as part of a retrofit solution.

As such, the WindTIMIZER functions as a mediator between the controller and the WindEYE™ system without the necessity of actually altering anything in the wind turbine controller at all.



## Operational achievements:

- 3% power increase verified by Windar and the turbine OEM
- Wind bin-based alignment system to reduce loads especially during high wind speed periods (potential down time not included in the power increase verification)
- Transfer function verification

## Other operational benefits:

- On-line access to operational wind data
- Real time turbulence intensity data available – primarily verifying wake sector management
- NEW feature (January 2022) rotor imbalance detection

## Example from verification report:

### Summary of 07K04 results:

1. Misalignment:
  - WT off: 7 deg
  - WT on: 0.8 deg
2. Yaw activity:
  - WT off: 16.2 deg/hour
  - WT on: 16.4 deg/hour
3. AEP gain:
  - With Lidar corrected wind speed : **3.3 %** based on:
    - 11.9 days of turbine operation / **Toggle: On**
    - 11.86 days of turbine operation / **Toggle: Off**
  - With sensor wind speed : **3.4%** based on:
    - 24.35 days of turbine operation / **Toggle: On**
    - 24.43 days of turbine operation / **Toggle: Off**

### Turbine 07K04 – Windar 1226

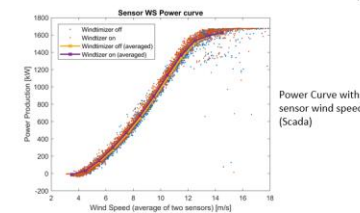
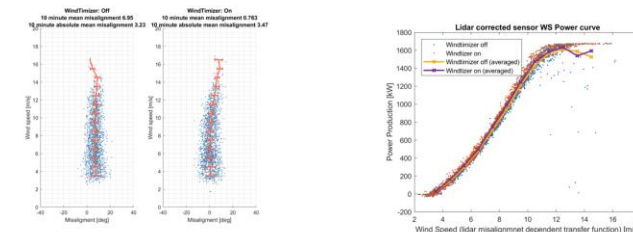

For detailed project verification – see separate Verification reports from Windar and the OEM

## **Additional Services – Retro-fit market:**

- **Nacelle transfer function evaluation**
  - **Wake Analysis**
  - **Rotor Imbalance Detection**

## Nacelle transfer function:

Nacelle Transfer Function (NTF) is applied to the nacelle anemometry signals to account for the influence of turbine's rotor and nacelle on the wind speed measurements. It represents the relationship between the free flow speed and the wind speed captured by the nacelle sensors.

- **Overestimating NTF** will lead to production losses caused by earlier cut out of the turbine.
- **Underestimating NTF** will lead to turbine operation above specification, increasing maintenance & potentially damaging the turbine

## Nacelle transfer function evaluation

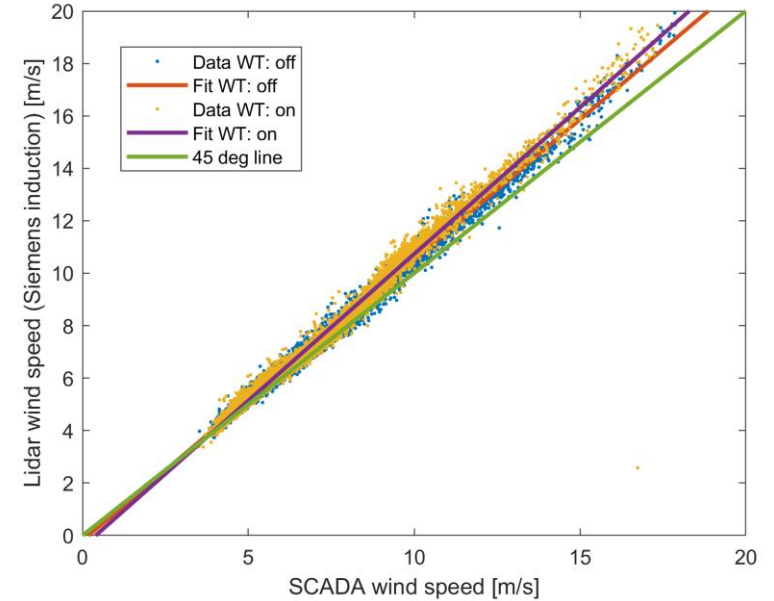
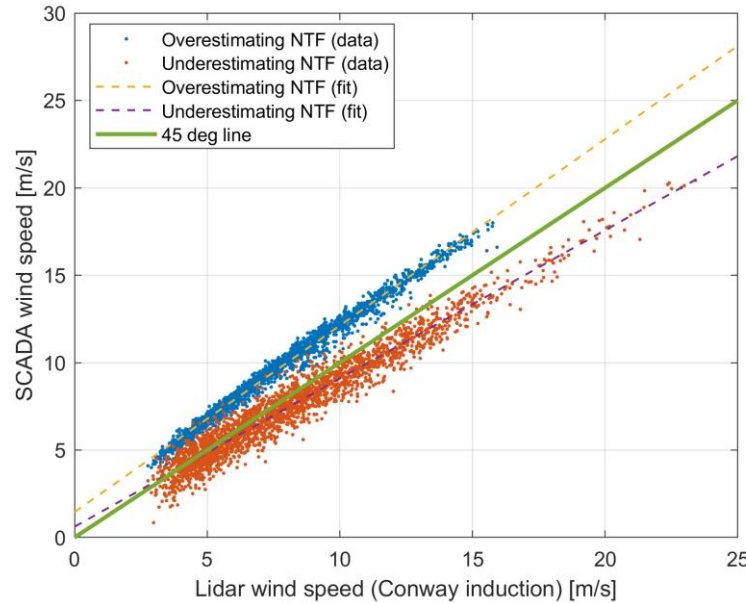

Examples of overestimating(blue) & underestimating(orange) NTF, taken from Windar campaigns in 2020-2021.

NTF evaluation	Cut-in ( specification-real) [ m/s]	Cut-out ( specification-real) [ m/s]	Result
Overestimating wind speed	4 - 2.5	25 - 21.9	AEP Loss 1.5 %
Underestimating wind speed	4 - 4.3	25 - 27.4	Increased loads

Expected outcome of inaccurate transfer function.



# **Windar Services: Wake Analysis**

## Sector Management (NE sector):

1. Turbine 261: **95h/year** under sector management. The turbine is not affected by wake at this sector, thus sector managed unnecessarily. The sector management applies for wind speeds larger than 10 m/s.
2. Turbine 260: **23h/year** under sector management. 99 % of this time the upstream turbine (T261) is not operating due to sector management, thus turbine 260 is sector managed unnecessarily for **22.7h /year**
3. Turbine 259: 23h/year under sector management. 97 % of this time the upstream turbine (T260 & T259) is not operating due to sector management, thus turbine 260 is sector managed unnecessarily for **22.4h /year**
4. The sector management on the NE sector leads to unnecessary losses of **150 MWh/year**.

## Wake sector management Cluster: T261/T260/T259, NorthEast sector (10-90 deg)

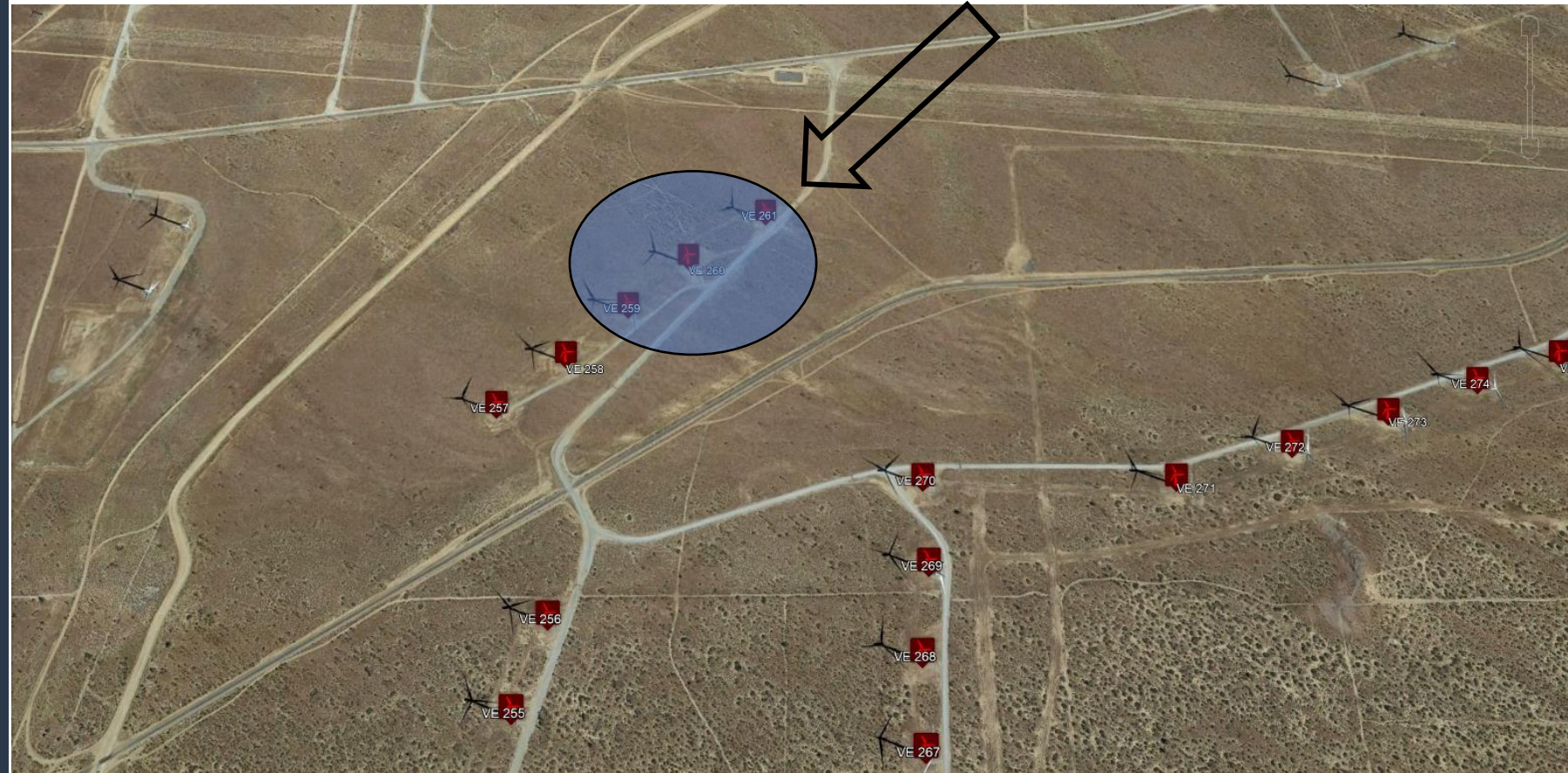

# Wake sector management

## Turbulence levels evaluation

### Windar Wake Analysis:

1. Wake sectors can be optimized based on true turbulence measurements
2. With the True North Verification, unnecessary derating due to the Nacelle position measurement error can be avoided.

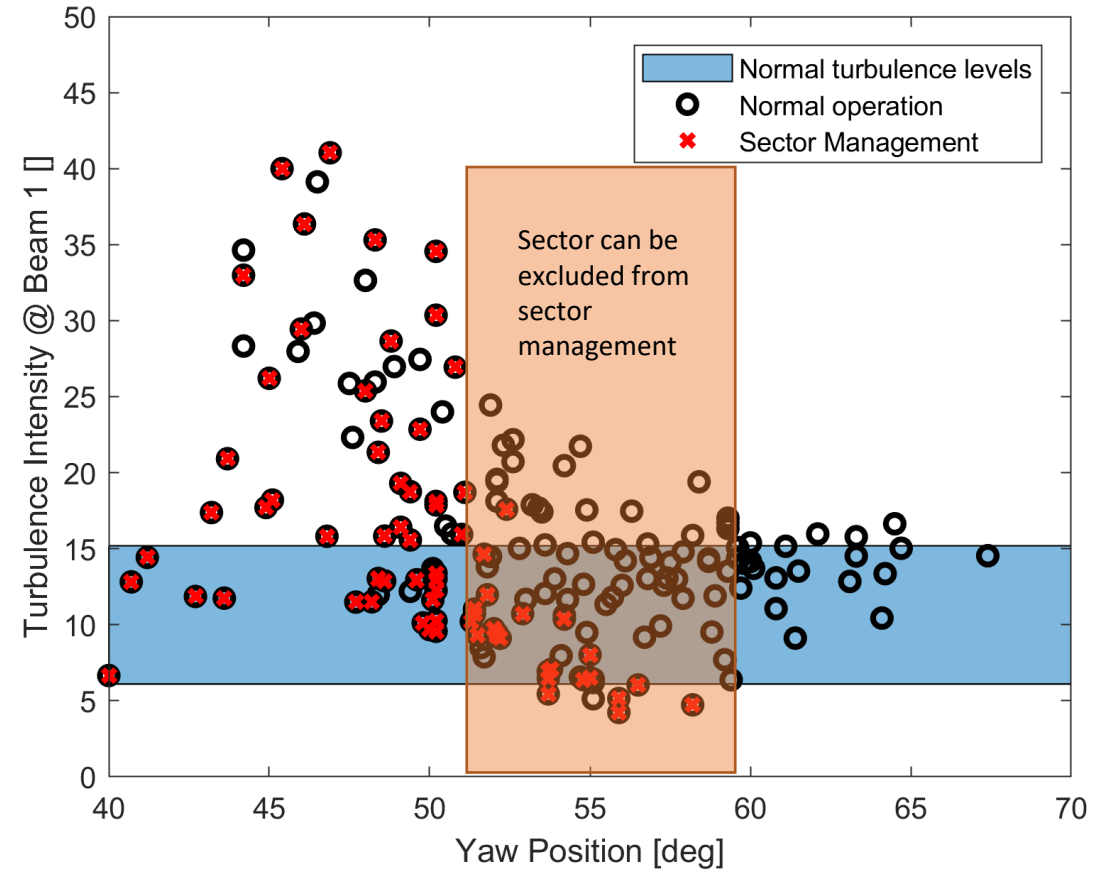

**Windar Services:  
Rotor Imbalance Detection**

# Rotor Imbalance – Pitch Misalignment

## Rotor Imbalance:

1. Pitch misalignment results in significant power losses
2. Extreme increase in yaw bearing moment.
3. Detection and correction of pitch misalignment would lead to significant power gains & load reduction.

Currently developing a method to identify rotor imbalance using WindEYE sensors.

